

Version 1.0

GBP24V SERIES

**Product manual of lithium iron
phosphate battery for communication**

USER MANUAL

NEW ENERGY TECHNOLOGY -- LIFE CHANGING

CONTENTS

| | | |
|-------|---|----|
| I、 | Installation Introduction | 1 |
| | 1.1 Carry or move | 1 |
| | 1.2 Unpacking inspection | 1 |
| | 1.3 Installation | 1 |
| II、 | Product Introduction | 1 |
| | 2.1 Specification | 2 |
| III、 | Product Performance | 2 |
| IV、 | System Description | 3 |
| | 4.1 Working mode | 3 |
| | 4.2 LED indicator description | 3 |
| | 4.3 Functional description | 4 |
| | 4.4 Power on / Power off | 6 |
| | 4.5 Product picture and Data sheet | 6 |
| V、 | Communication description | 8 |
| | 5.1 RS485 Communication | 8 |
| | 5.2 CAN Communication | 11 |
| VI、 | Maintenance and troubleshooting | 16 |
| | 6.1 Daily maintenance | 16 |
| | 6.2 Caution | 16 |
| VII、 | Warranty | 17 |
| VIII、 | Lithium battery management requirements | 17 |

I. Installation Introduction

1.1 Carry or move

During the transportation or movement of the lithium battery, avoid carrying it upside down or sleeping on its side, and handle it carefully to avoid collisions.

1.2 Unpacking inspection

Check whether the battery is damaged during transportation.

Check accessories:

Parallel cable and communication cable (Configure as required)

1.3 Installation

1.3.1 Prepare before installation

Determine the installation environment and location

Laying the connecting wires

Installation tools (A Phillips screwdriver)

1.3.2 Installation environment and location

The battery needs to be installed in a ventilated and dry environment.

Considering that the battery adopts natural air cooling, the battery should not be too close to the heat source to ensure the ambient temperature and maintenance space around the battery.

Do not place the battery in any of the following environments.



High temperature



Rain



Fire source



corrosion

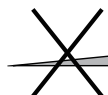

Slope

II. Product Introduction

This product is composed of high-quality lithium iron phosphate batteries (by series and parallel) plus an advanced BMS battery management system. It can be used as an independent DC power supply or as a "basic unit" to form a variety of specifications of energy storage lithium battery power systems. High reliability and long life. It can be used as a backup power supply for communication base stations, a backup power supply for a digital center, a home energy storage power supply, an industrial energy storage power supply, etc.

2.1 Specification

| Configuration | Data | Function |
|-----------------------|------------|---------------------------------------|
| Single cell | 3.2V | |
| No of series | 8 S | 16S option |
| Capacity | 50AH/100AH | Settable/ Maximum can be 20 parallels |
| Limit function | No | Option |
| LCD | No | Option |
| Storage function | Yes | |
| Heating function | No | Option |
| Pre-charging function | Yes | |
| Communication | RS485 | CAN Option |

III. Performance

The product adopts modular design, higher integration, and saves installation space; adopts high-performance lithium iron phosphate cathode material, good battery core consistency, and designed service life of more than 10 years; one-key switch machine, front operation, front wiring, convenient installation Convenient maintenance and operation; diverse functions, over-temperature alarm protection, over-charge and over-discharge protection, short-circuit protection; strong compatibility, can be seamlessly connected with UPS, photovoltaic power generation and other main equipment; various forms of communication interfaces, CAN/RS485, etc. can be based on Customized according to customer needs to facilitate the flexible use of system remote monitoring. High-energy, low-power lithium battery equipment achieves higher energy supply, lower energy consumption, and reduces environmental pollution; adopts all-round, multi-level battery protection strategies and fault isolation measures to ensure the safe operation of the system.

- Small size and light weight
- Maintenance-free
- Environmental protection and pollution-free materials, no heavy metals, green and environmental protection
- The standard cycle life exceeds 5000 times
- Accurately estimate the state of charge of the battery pack, that is, the remaining power of the battery, to ensure that the power of the battery pack is maintained within a reasonable range
- Built-in BMS management system with comprehensive protection and monitoring and control functions

IV. System description

This product has a full-featured 8-16 series lithium-ion battery pack management system, with protection and recovery of monomer over-voltage/under-voltage, total voltage under-voltage/over-voltage, charge/discharge over-current, high temperature, low temperature, and short circuit. Features. Realize accurate SOC measurement during charging and discharging, and SOH health status statistics. Achieve voltage balance during charging. Data communication with the host is carried out through RS485 communication, parameter configuration and data monitoring are carried out through the human-computer interaction of the upper computer software, the communication with the host is carried out through 485 or CAN communication, and the parameter configuration and data monitoring are carried out through the human-computer interaction of the upper computer software. (The baud rate of the host computer is 9600 or 19200).

4.1 Working mode

- **Charging mode:** When the BMS detects that the charger is connected and the external charging voltage is greater than the internal battery voltage by more than 0.5V, it will turn on the charging MOSFET for charging. When the charging current reaches the effective charging current, the charging mode is entered. In charging mode, the charge and discharge MOSFETS are both closed.
- **Discharge mode:** When the BMS detects the load connection and the discharge current reaches the effective discharge current, it enters the discharge mode.
- **Standby mode:** When the above two modes are not satisfied, enter the standby mode.
- **Shutdown mode (default closed):** Normal standby for 24 hours, battery triggers under-voltage protection, execute button shutdown, BMS enters shutdown mode. Wake-up conditions in shutdown mode: 1. Charge activation; 2. Press key to turn on;

4.2 LED indicator introduction

LED light sequence, 1 running light, 1 alarming light, 4 capacity indicators



- **Capacity indication**

| Status | Chg | | | | | Dischg | | | | |
|--------------|-------|-------|-------|-------|-------|--------|-----|-----|-----|----|
| LED Capacity | L4 | L3 | L2 | L1 | Flash | L4 | L3 | L2 | L1 | On |
| 0~25% | Off | Off | Off | Flash | Flash | Off | Off | Off | Off | On |
| 25~50% | Off | Off | Flash | On | On | Off | Off | On | On | On |
| 50~75% | Off | Flash | On | On | On | Off | On | On | On | On |
| ≥75% | Flash | On | On | On | On | On | On | On | On | On |
| LED Running | On | | | | | Flash | | | | |

● Status indication

| System status | Running status | Run | ALM | SOC | | | | Remarks |
|---------------|---|--------|--------|---------------------------------|-----|-----|-----|---------------------------------|
| | | ● | ● | ● | ● | ● | ● | |
| Power off | Sleep | Off | Off | Off | Off | Off | Off | All Off |
| Standby | Normal | Flash1 | Off | According to the power capacity | | | | Standby status |
| | Alarm | Flash1 | Flash1 | | | | | |
| Charging | Normal | On | Off | According to the power capacity | | | | |
| | Over-current Alm | On | Flash2 | According to the power capacity | | | | |
| | Over-volt protection | Flash1 | Off | Off | Off | Off | Off | Max.LED flash2 |
| | Over-temperature/over-current protection | Flash1 | Off | Off | Off | Off | Off | |
| Discharging | Normal | Flash3 | Off | According to the power capacity | | | | According to the power capacity |
| | Alarm | Flash3 | Flash3 | | | | | |
| | Over-temperature /over-current/short circuit protection | Off | On | Off | Off | Off | Off | Stop discharging, forced |
| | Under-vol protection | Off | Off | Off | Off | Off | Off | Stop discharging |

4.3 Functional description

● Standby state: After the BMS is correctly connected and powered on, and there is no protection state of over-voltage, under-voltage, over-current, short circuit, over-temperature, under-temperature, etc., press the reset button to turn on the device, and the BMS is in standby state.

In the BMS standby state, the running light flashes, and the battery can be charged and discharged.

● Cell overcharge protection and recovery: When any section of the battery cell is higher than the set value of cell overcharge protection, the BMS enters the overcharge protection state, and the charging device cannot charge the battery.

After cell over-voltage protection, when the highest cell voltage drops below the cell overcharge recovery value and the SOC is lower than 96%, the overcharge protection state is released. It can also be discharged.

● Total voltage overcharge protection and recovery: When the battery voltage is higher than the total voltage overcharge protection setting value, the BMS enters the overcharge protection state, and the charging device cannot charge the battery. When the total voltage drops below the total overcharge recovery value and the SOC is lower than 96%, the overcharge protection state is released. It can also be discharged.

● Single over-discharge protection and recovery: When any section of the battery cell is lower than the set value of the single over-discharge protection, the BMS enters the over-discharge protection state, and the load cannot discharge the battery. BMS shuts down after 1 minute of communication.

After over-discharge protection occurs, charging the battery pack can release the over-discharge protection state. Or press the reset button once, and the BMS will turn on and re-check whether the battery pack voltage reaches the restored value.

● Total voltage over-discharge protection and recovery: When the battery voltage is lower than the total voltage over-discharge protection setting value, the BMS enters the over-discharge protection state, and the load cannot discharge the battery. BMS shuts down after 1 minute of communication.

After over-discharge protection occurs, charging the battery pack can release the over-discharge protection state. Or press the reset button once, and the BMS will turn on and re-check whether the battery pack voltage reaches the restored value.

- **Charge over-current protection and recovery:** When there is no charge current limit function, the charge over-current protection can be triggered.

When the charging current exceeds the charging over-current protection setting value, and the delay time is reached. The BMS enters the charging over-current protection, and the charging device cannot charge the battery.

After charging over-current protection occurs, the BMS will automatically delay recovery and re-detect the external charger current. Discharge can also release the charge over-current protection.

- **Discharge over-current protection and recovery:** When the discharge current exceeds the discharge over-current protection setting value, and the delay time is reached. The BMS enters the discharge over-current protection, and the load cannot charge the battery.

After discharge over-current protection occurs, the BMS will automatically delay recovery and re-detect the external load current. Charging can also release the discharge over-current protection.

The discharge over-current protection has two levels of protection, which can restore the transient over-current protection as well as the discharge over-current protection. The transient over-current protection will be locked when the condition is reached, and it must be turned off and turned on or the charging is released.

- **Temperature protection and recovery:** BMS has 6 temperature detection ports, which implement protection measures by monitoring temperature changes.

- **Charging and discharging high temperature protection and recovery:** When charging and discharging, when any of the 4 batteries NTC is higher than the high temperature protection setting value, the BMS enters the high temperature protection. The BMS stops charging or discharging.

When the cell temperature is lower than the high temperature recovery value, the BMS resumes charging or discharging.

- **Charging and discharging low-temperature protection and recovery:** When charging and discharging, when the NTC of 4 batteries is below the low-temperature protection setting value, the BMS enters the low-temperature protection. The BMS stops charging or discharging.

When the cell temperature is higher than the low temperature recovery value, the BMS resumes charging or discharging.

- **Environmental temperature alarm, power temperature protection:** When NTC detects that the ambient temperature is higher than the set value of ambient high temperature, the BMS generates an alarm. BMS will not stop charging and discharging.

When NTC detects that the power temperature is higher than the power protection setting value, the BMS enters the power high temperature protection. Stop charging and discharging.

- **Equalization function:** The BMS has standby and charge equalization functions. The BMS system uses an energy-consuming equalization circuit, and the equalization opening voltage is adjustable by software. Any section of the equalization opening condition is higher than the equalization opening voltage and the pressure difference meets the conditions.

The equalization stops when charging is stopped or the cell voltage difference is less than the set value.

4.4 Power on/power off

| No | Function | Desp |
|----|-------------------|---|
| 1 | Power on/Start | When the BMS is in the dormant state, press the reset button once, the BMS will be activated, and the LED indicator will flash in turn, then it will enter the normal working state. |
| 2 | Power off/dormant | When the BMS is in the standby or discharging state, press this key for 3 seconds, the BMS will be dormant, the LED indicator will flash in turn, then it will enter the dormant state. The BMS has no power consumption after sleep. |

4.5 Product picture and data sheet



▲ RACK TYPE

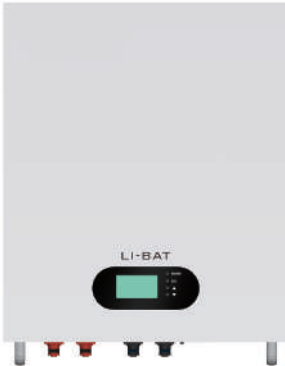

▲ POWER WALL

| Model | GBP24V-50AH | GBP24V-100AH |
|---|--------------------------------------|---------------|
| Nominal volt (V) | 24 | |
| Nominal capacity (AH) | 50 | 100 |
| Working volt range | 22.4-30 | |
| Recommend charging volt (V) | 28 | |
| Recommend discharging cutoff volt (V) | 23.2 | |
| Standard charging current(A) | 25 | 50 |
| Max. Constant charging current(A) | 50 | 100 |
| Standard discharging current (A) | 25 | 50 |
| Max. Discharging current (A) | 50 | 100 |
| Temperature (C) | -30 C ~ 60 C (Recommend 10 C ~ 35 C) | |
| Allowable humidity range | 0 ~ 85% RH | |
| Storage temperature (C) | -20 C ~ 65 C (Recommend 10 C ~ 35 C) | |
| Protection | IP20 | |
| Cooling method | Natural air cooling | |
| Maximum Dimension (W*D*H) for rack type | 482.6*360*175 | 482.6*535*175 |
| Net Weight | 15KG | 30KG |

V. Communication introduction

5.1 RS485 communication

The BMS has RS485 communication for battery pack assembly, and the baud rate is 9600bps. RS485 communication interface adopts 8P8C network cable interface.

RS485 Communication interface definition:

| Pin | definition |
|------|------------|
| 1、 8 | RS485-B |
| 2、 7 | RS485-A |
| 3、 6 | |
| 4、 5 | NC |

RS485 communication:

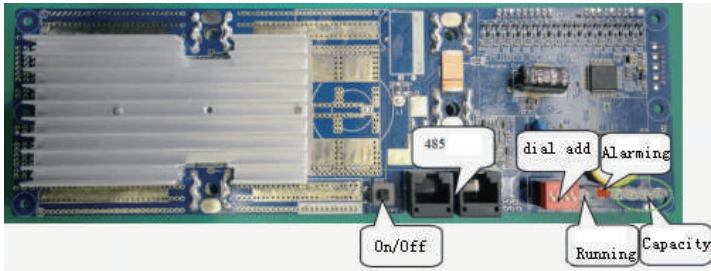

Parallel communication cautions

For safe operation and compliance, it is necessary to check whether the appearance of each battery pack is damaged before paralleling. If there is no such situation, press the start button of the battery pack, visually check whether the LED indicator is normal, and then use the multimeter to measure the voltage value of each battery pack in turn. When the battery pack voltage difference exceeds 0.5V, it cannot be directly connected in parallel. The battery pack needs to be charged and discharged separately so that the voltage difference is within 0.5V, and then can be connected in parallel.

When connecting in parallel, each battery pack must be turned off and use the parallel cable provided by us to ensure that the positive terminal (+) on the battery pack is connected to the positive terminal (+), the negative terminal (-) is connected to the negative terminal (-) and tighten the bolts. When the connection is complete, turn on each battery pack in turn.



All wiring must be performed by professionals.

Parallel communication

When multiple machines are connected in parallel, the RS485 interface is used as the parallel communication interface, and the CAN interface is used as the uplink communication interface. The terminal device can read the sum of the battery data of all parallel PACKs through the CAN interface.

Dialing address selection

Parallel DIP switch definition: For multi-machine communication when battery packs are connected in parallel, the DIP switch is used to distinguish different pack addresses. The hardware address can be set by the DIP switch on the board. Refer to the table below for the definition of the DIP switch.

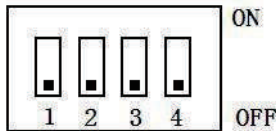

| Add | DIP switch position | | | | Remarks |
|-----|---------------------|-----|-----|-----|---------|
| | #1 | #2 | #3 | #4 | |
| 0 | OFF | OFF | OFF | OFF | Pack0 |
| 1 | ON | OFF | OFF | OFF | Pack1 |
| 2 | OFF | ON | OFF | OFF | Pack2 |
| 3 | ON | ON | OFF | OFF | Pack3 |
| 4 | OFF | OFF | ON | OFF | Pack4 |
| 5 | ON | OFF | ON | OFF | Pack5 |
| 6 | OFF | ON | ON | OFF | Pack6 |
| 7 | ON | ON | ON | OFF | Pack7 |
| 8 | OFF | OFF | OFF | ON | Pack8 |
| 9 | ON | OFF | OFF | ON | Pack9 |
| 10 | OFF | ON | OFF | ON | Pack10 |
| 11 | ON | ON | OFF | ON | Pack11 |
| 12 | OFF | OFF | ON | ON | Pack12 |
| 13 | ON | OFF | ON | ON | Pack13 |
| 14 | OFF | ON | ON | ON | Pack14 |
| 15 | ON | ON | ON | ON | Pack15 |

Note: When in parallel, the battery pack address dial code is set from Pack1 downward.

two pieces in parallel diagram

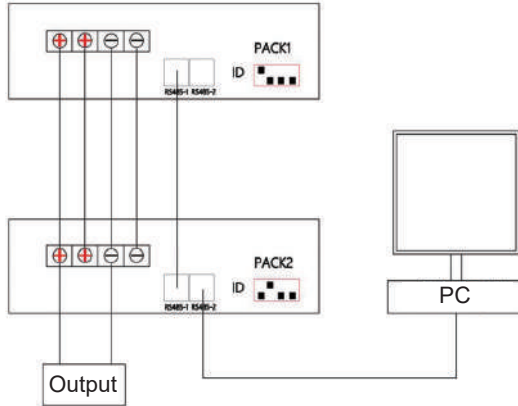

Three pieces in parallel diagram

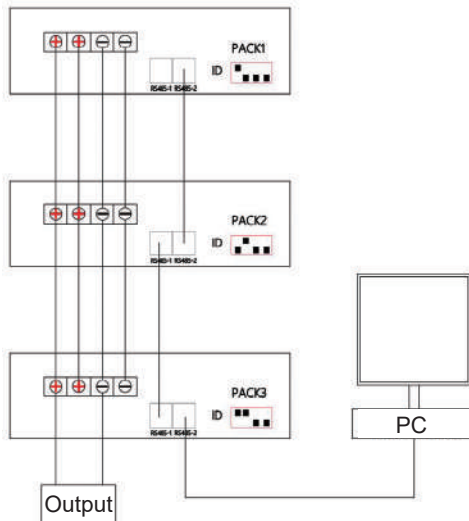

Four pieces in parallel diagram

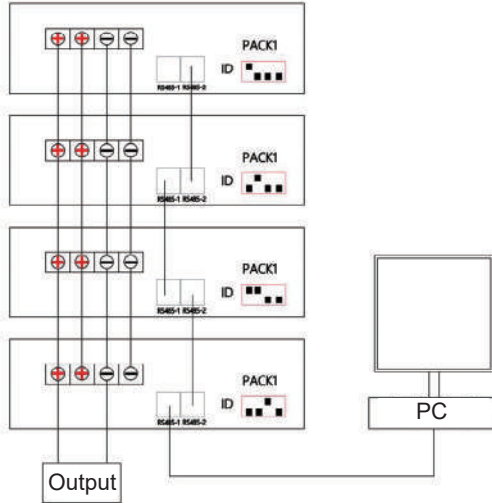

▲ For more parallel machines, refer to the above parallel machine diagram and increase in order.

5.2 CAN Communication

The BMS has the CAN communication function for uploading battery packs, and the CAN communication interface adopts the 8P8C network cable interface. It can communicate with inverter or CAN TEST through CAN interface. When the battery pack is assembled, connect through RS485 communication, and finally upload the battery pack data, status and information to PCS through CAN communication.

CAN communication interface definition:

| Pin | Definition |
|---------|------------|
| 1、2、7、8 | NC |
| 4 | CAN-L |
| 5 | CAN-H |
| 3、6 | |

CAN communication :

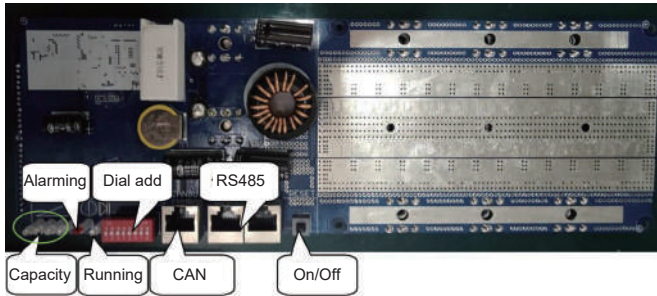

Dialing address selection

Parallel DIP switch definition: When the battery pack is connected in parallel, use the DIP switch to distinguish different pack addresses, and the hardware address can be set by the DIP switch on the board.

Stand-alone address setting: 0000 0000

Parallel address setting: Refer to the table below for the definition of the DIP switch.

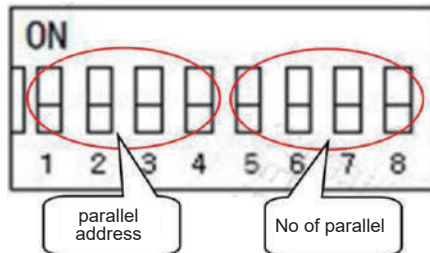

Slave address

| Add | DIP switch position | | | | remarks |
|-----|---------------------|-----|-----|-----|---------|
| | #1 | #2 | #3 | #4 | |
| 1 | ON | OFF | OFF | OFF | Pack1 |
| 2 | OFF | ON | OFF | OFF | Pack2 |
| 3 | ON | ON | OFF | OFF | Pack3 |
| 4 | OFF | OFF | ON | OFF | Pack4 |
| 5 | ON | OFF | ON | OFF | Pack5 |
| 6 | OFF | ON | ON | OFF | Pack6 |
| 7 | ON | ON | ON | OFF | Pack7 |
| 8 | OFF | OFF | OFF | ON | Pack8 |
| 9 | ON | OFF | OFF | ON | Pack9 |
| 10 | OFF | ON | OFF | ON | Pack10 |
| 11 | ON | ON | OFF | ON | Pack11 |
| 12 | OFF | OFF | ON | ON | Pack12 |
| 13 | ON | OFF | ON | ON | Pack13 |
| 14 | OFF | ON | ON | ON | Pack14 |
| 15 | ON | ON | ON | ON | Pack15 |

Host address

| No of parallel | DIP switch position | | | | Remarks |
|----------------|---------------------|-----|-----|-----|----------------|
| | #5 | #6 | #7 | #8 | |
| 2 | ON | OFF | OFF | OFF | 2 in parallel |
| 3 | OFF | ON | OFF | OFF | 3 in parallel |
| 4 | ON | ON | OFF | OFF | 4 in parallel |
| 5 | OFF | OFF | ON | OFF | 5 in parallel |
| 6 | ON | OFF | ON | OFF | 6 in parallel |
| 7 | OFF | ON | ON | OFF | 7 in parallel |
| 8 | ON | ON | ON | OFF | 8 in parallel |
| 9 | OFF | OFF | OFF | ON | 9 in parallel |
| 10 | ON | OFF | OFF | ON | 10 in parallel |
| 11 | OFF | ON | OFF | ON | 11 in parallel |
| 12 | ON | ON | OFF | ON | 12 in parallel |
| 13 | OFF | OFF | ON | ON | 13 in parallel |
| 14 | ON | OFF | ON | ON | 14 in parallel |
| 15 | OFF | ON | ON | ON | 15 in parallel |

Two piece in parallel diagram

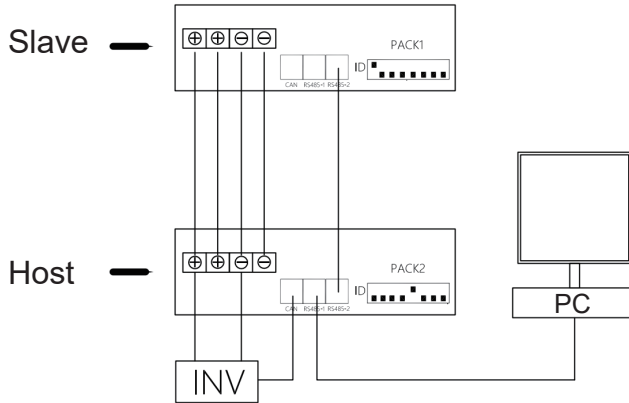

Three piece in parallel diagram

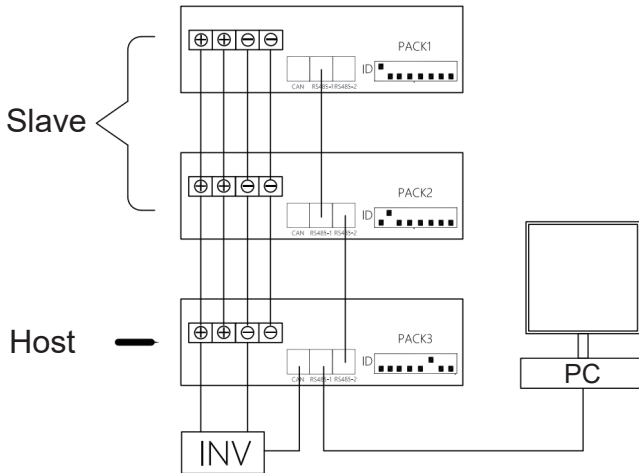

Four pieces parallel diagram

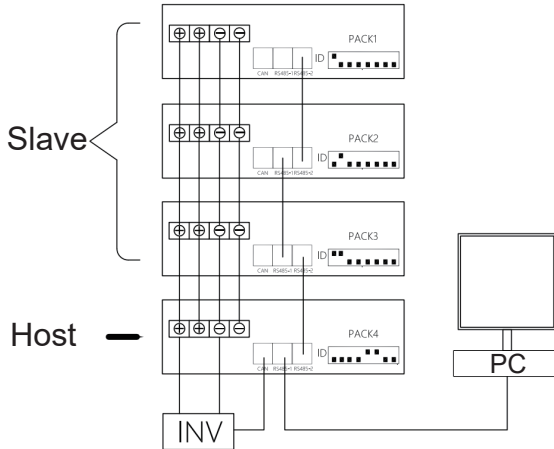

▲ For more parallel machines, refer to the above parallel machine diagram and increase in order.

VI. Maintenance and troubleshooting

6.1 Daily maintenance

- A. Regularly (6 months) clean the battery dust and check whether the battery connection wires are loose.
- B. If there is no power failure for a long time, it is recommended to discharge the battery artificially every 6 months.
- C. If the battery is found to be bad, the entire battery pack should be replaced in time.
- D. Try to avoid deep discharge of the battery. The recommended cut-off discharge voltage is 45V.

Note: During maintenance, metal items such as rings and watches must be taken off. Use tools with insulated handles.

6.2 Cautions

- A. The battery management system cannot be used in series
- B. The battery management system cannot use a charge-discharge cabinet above 100V for charge-discharge cycles.
- C. Pay attention to anti-static, moisture-proof and waterproof during use.

D. Please follow the design parameters and conditions of use during use, and do not exceed the values in this specification, otherwise the protection board may be damaged.



If you need to use inverters from other manufacturers, please communicate with our engineers in advance

VII. Warranty

Under the guidance of our company, customers return our company's products so that our company can provide maintenance services. Service or replace products of the same value. Customers need to pay the necessary freight and other related expenses.

Any replacement or repair of the product will cover the remaining warranty period of the product. During the warranty period, if the production. If any part of the product or product is replaced by our company, the ownership of the replaced product or part. The benefits belong to Jiangsu GSO New Energy Technology Co., Ltd.

Product warranty service does not cover damage caused by the following reasons:

- Damage during the transportation of the equipment (except for those transported by Jiangsu GSO New Energy Technology Co., Ltd.)
- Damage caused by improper installation or debugging
- Damage caused by failure to follow the operation manual, installation manual or maintenance instructions
 - Modify, change or repair the damage caused by the product by yourself
 - Damage caused by improper use or operation
 - Damage caused by insufficient ventilation of equipment
 - Damage caused by non-compliance with applicable safety standards or related regulations
- Damage or force majeure caused by natural disasters (floods, lightning, overvoltage, storms, snow, fire, etc.)

In addition, normal wear and tear or any other malfunctions will not affect the basic operation of the product. Any external Scratches, stains or natural mechanical abrasion do not mean that the product is defective.

VIII. Lithium battery management requirements

Because lithium is a metal that is particularly prone to chemical reactions, it is easy to extend and burn, so if it is not handled in accordance with regulations during

packaging, transportation, and storage, it may cause serious accidents-combustion and explosion.

In order to prevent casualties and property losses caused by improper handling of lithium batteries in daily life, the following requirements are imposed on lithium battery management:

1. Basic requirements for battery warehouse management:

Due to the characteristics of lithium batteries, high temperature and humidity will accelerate the self-discharge of the battery. It is recommended that the battery without opening the package should be stored in a clean, dry and ventilated warehouse with an ambient temperature of $-5\text{ }^{\circ}\text{C} \sim 35\text{ }^{\circ}\text{C}$ and a relative humidity of not more than 90%. Inside, the warehouse should not contain corrosive gas.

Humidity requirements: effectively control the humidity of the warehouse to avoid extreme humidity (relative humidity higher than 90%) for a long time.

Lithium battery warehouses should be physically separated by brick walls. The warehouses must be enclosed, explosion-proof or other corresponding safety electrical lighting equipment.

The place where the battery is stored should be equipped with sufficient types of fire-fighting equipments (such as carbon dioxide, dry powder fire extinguisher, fire hose, fire-fighting sandbox) and ensure that it is in good condition. It is recommended to install an automatic rain sprinkler fire extinguishing system if possible. It cannot be placed in the same warehouse with flammable materials (such as packaging materials, cartons, cartons, etc.), and a separate warehouse is recommended.

Where there are lithium batteries, there must be some illegal regulations such as prohibiting smoking.

The battery pack should be far away from fire and heat sources, and operations that may cause fires are not allowed in the warehouse or site where the battery is stored.

2. Good battery storage requirements:

The battery should be stored in a well-ventilated, dry and cool place. High temperature and high humidity may damage the battery performance or corrode the battery surface.

The battery packing box should not be stacked higher than the arrival height when the materials are received, otherwise the batteries in the bottom box may be deformed and liquid leakage may occur.

The battery should not be stored or displayed in direct sunlight or places exposed to rain. If the battery is drenched, the insulation resistance will decrease, and self-discharge and rust may occur. A rise in temperature may damage the battery.

Store and display the batteries in their original packaging to avoid random stacking of the batteries after the packaging is removed, which may cause short circuits and damage to the batteries.

Items that are likely to cause combustion or explosion when they come into contact with each other and items with different fire fighting methods should be stored separately.

After the production is completed, when the surplus battery is returned to the warehouse, the original packaging state (insulation) needs to be restored first and then stored.

3. Defective battery storage requirements

In case of serious defects such as leakage, bump damage, short circuit, etc. of defective

batteries and modules returned from production, the following measures must be taken:

A) Battery and module defective products warehouses need to be set up separately, and the warehouses shall be physically separated by brick walls, and shall be equipped with sufficient varieties of fire-fighting equipments and alarm facilities.

B) Defective batteries and modules that have a fire risk determined by technology and quality are immediately buried in the sandbox and moved to an open outdoor area to prevent fire, and subsequently notify a professionally qualified hazardous waste treatment unit for disposal, and do a good job Handling of disposal procedures.

For batteries and modules with poor general performance (size, capacity, appearance, etc.). Take the following measures:

A) Batteries and modules that have been judged by technology and quality are only general failures: If the incoming materials are bad, notify the purchasing department to return the goods in time. If the operation is poor and it is determined that repairs cannot be made, after completing the disposal application, timely notify a qualified hazardous waste disposal unit for disposal.

B) For bad batteries during the storage period, after the battery is insulated (to prevent accidental short circuit), try to restore the original factory packaging to ensure that the battery is safely and well protected.

4. Other requirements

The warehouse management personnel should check the cargo information every day. If they find that the storage location is incorrect, the accounts are not consistent, and the quality problems are reported and dealt with in a timely manner, they should conduct a fire protection inspection and cut off the power after the work is finished or after get off work.

Keep safe passages in the warehouse unblocked, prevent accumulations, and ensure the safety of personnel and the rapid transfer of goods. The planning storage area in the warehouse must be clearly marked, and the material storage area must be classified and stored in small areas (in the event of a fire, to avoid spreading to the maximum extent) and clearly marked.

Clean and tidy up the warehouse area every day, clean up dirt and debris on the ground in time, and organize the materials in the warehouse into the designated area to meet the requirements of tidy, clean, hygienic and reasonable placement.

Follow the "first in, first out" principle to avoid battery performance degradation and accidents caused by long-term inventory.

The end! Thank you for your reading!

GBP24V SERIES

Product manual of lithium iron

phosphate battery for communication